

SMARTFLOW® Flow Regulators

Why use SMARTFLOW Flow Regulators?

- ◆ **Create Repeatable and Balanced Processes**
Multiple circuits within an injection mold often have different cooling requirements. Cooling water will normally follow the path of least resistance leaving some circuits starved for water in manifolds without regulators. Individual circuit control allows the operator to direct the process cooling water where needed to produce repeatable finished part quality.
- ◆ **Optimize Cooling Capacity**
By applying the principles of Turbulent Flow, cooling circuits can be optimized for efficient cooling, conserving water and electricity. Additional water flow rate beyond turbulent flow condition provides diminishing returns illustrated by the chart below.

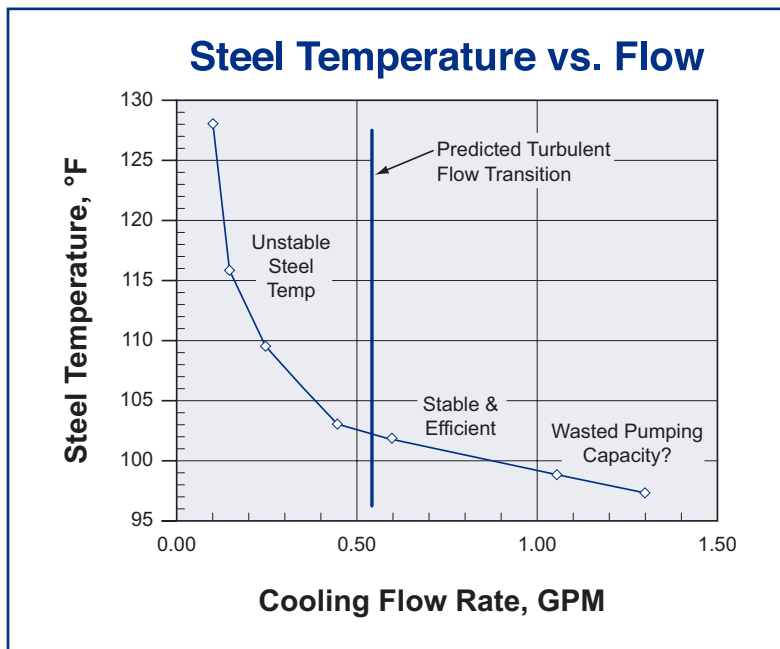

Try our On-Line Calculators for Injection molders accessible from the home page:

www.SMARTFLOW-USA.com

Scientific Cooling Calculator extracts cooling water flow rate, heat transfer, processing temperatures, and overall cooling requirements based on polymer type, processing temperature, shot weight and other variables.

Turbulent Flow Calculator flow rate needed to achieve turbulence based on the Reynolds Number, cooling water temperature and inside diameter of the cooling channel.

- ◆ **Implement Scientific CoolingSM**
Flow Regulators help injection molders use the three R's of Scientific Cooling: Reveal, Record, Repeat.

Burger & Brown Engineering recommends placing flow regulators on the return side of the cooling water loop. This position ensures that the cooling lines are full of cooling water. Regulators placed on the supply side may provide only a small stream of water to the cooling lines. The water may not come in contact with all internal cooling surfaces providing inconsistent part cooling.

Using Smartflow Flow Regulators to apply the principles of Turbulent Flow and Scientific Cooling, injection molders optimize cooling water and energy efficiency while providing the best possible environment to make repeatable parts.



For 3D CAD files of Custom Manifold Assemblies and Standard Components Visit

ManifoldBuilder.com



Precision Flow Regulator Only

General Description

Delta-Q is a durable and economical precision flow regulator module that can be used in conjunction with other **SMARTFLOW** components such as:

- ◆ Threaded End Caps
- ◆ IceCube™ Flowmeters
- ◆ Temperature and Pressure Gauges
- ◆ Dr. Eddy® Flowmeter/Turbulent Flow Indicators
- ◆ Tracer® Electronic Flowmeters
- ◆ Cooling Water Manifolds

The Delta-Q Regulator allows full adjustability of flow volume from unrestricted flow to complete shut off using the manual flow control knob.

The modular design allows users to customize models meeting Scientific CoolingSM requirements for each application. The glass-filled nylon body is lightweight and durable. Internal stainless steel components are resistant to corrosion.

See page 16 for custom assembly specification onto manifolds.



FP3-F3-Q

Model Number

F3 - A - Q

Brass End Caps

1/4"NPT	F2
1/4"BSPP	F2B
3/8"NPT	F3
3/8"BSPP	F3B
1/2"NPT	F4
1/2"BSPP	F4B

Nylon End Caps

1/4"NPT	FP2
1/4"BSPP	FP2B
3/8"NPT	FP3
3/8"BSPP	FP3B
1/2"NPT	FP4
1/2"BSPP	FP4B

Accessories

A	Flowmeter only
B	Thermometer
C1	Thermometer and 30 psi Pressure Gauge
C2	Thermometer and 60 psi Pressure Gauge
C3	Thermometer and 100 psi Pressure Gauge
CL	Thermometer and Liquid-Filled Pressure Gauge (100 psi)
F1	30 psi Pressure Gauge
F2	60 psi Pressure Gauge
F3	100 psi Pressure Gauge
FL	Liquid-Filled Pressure Gauge (100 psi)

Wetted Parts and Materials

End Caps.....	Brass or Glass-Filled Nylon
Body	Glass-Filled Nylon
O-Rings	EPDM
Regulator Stem.....	Stainless Steel
Cap Screws	Stainless Steel
Optional Gauge Block.....	Brass
Optional Quick-Connect Fittings.....	Brass

Specifications

Operating Temperature max.....	210°F (99°C)
Operating Pressure max.....	100 psi (6.9 bar)
Dial Thermometer.....	0 to 250°F (-20° to 120°C)
	±2% accuracy (full scale)
Pressure Gauge	0 to 100 psi (0 to 700Kpa)
	±3% accuracy (full scale)

For customized assembly onto Smartflow Manifolds, see page 16 or visit www.manifoldbuilder.com

www.ManifoldBuilder.com

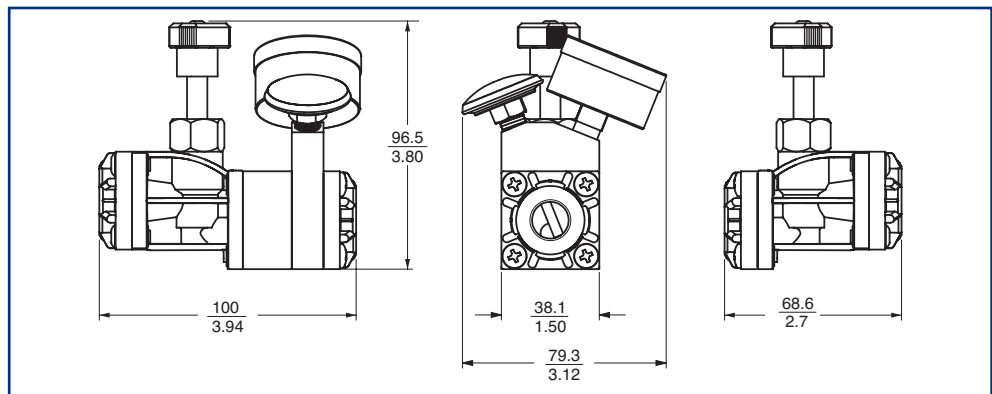



Precision Flow Regulator with IceCube™ Flowmeter

Model Number

F3 - A - 25 - Q

Brass End Caps

1/4"NPT	F2
1/4"BSPP	F2B
3/8"NPT	F3
3/8"BSPP	F3B
1/2"NPT	F4
1/2"BSPP	F4B

Nylon End Caps

1/4"NPT	FP2
1/4"BSPP	FP2B
3/8"NPT	FP3
3/8"BSPP	FP3B
1/2"NPT	FP4
1/2"BSPP	FP4B

Flow Range

15	0.2 - 1.5 gpm (gallons per minute)
25	0.5 - 2.5 gpm
80	1 - 8 gpm
100	2 - 10 lpm (liters per minute)
200	5 - 20 lpm
300	4 - 30 lpm



F3-A-80-Q

Accessories

Flowmeter only	A
Thermometer	B
Thermometer and 30 psi Pressure Gauge	C1
Thermometer and 60 psi Pressure Gauge	C2
Thermometer and 100 psi Pressure Gauge	C3
Thermometer and Liquid-Filled Pressure Gauge (100 psi)	CL
30 psi Pressure Gauge	F1
60 psi Pressure Gauge	F2
100 psi Pressure Gauge	F3
Liquid-Filled Pressure Gauge (100 psi)	FL

Wetted Parts and Materials

End Caps....Brass or Glass-Filled Nylon
 Flow Body.....Polysulfone
 Regulator Body..... Glass-Filled Nylon
 Vane Glass-Filled Nylon
 Spring Stainless Steel
 O-Rings EPDM
 Optional Gauge Block..... Brass

Specifications

Flow Accuracy ±10% full scale
 Operating Temperature max.....210°F
 (99°C)
 Operating Pressure max..... 100 psi
 (6.9 bar)
 Dial Thermometer.....0 to 250°F
 (-20° to 120°C)
 ±2% accuracy (full scale)
 Pressure Gauge0 to 100 psi
 (0 to 700Kpa)
 ±3% accuracy (full scale)

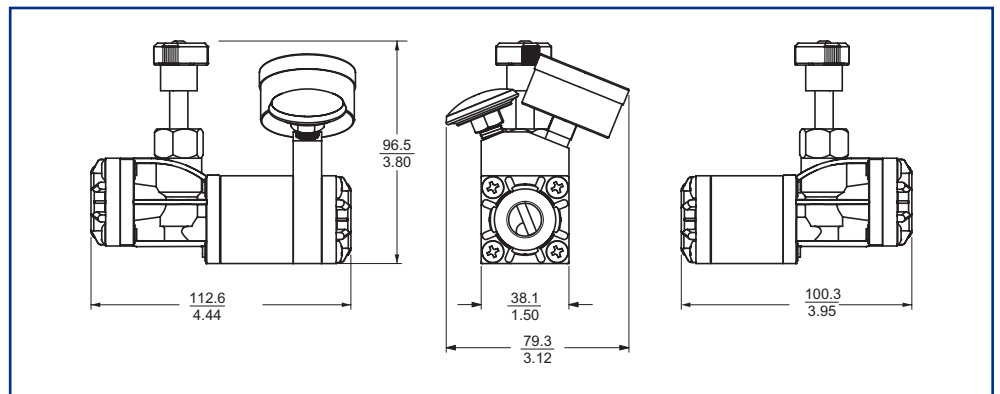



Precision Flow Regulator with Dr. Eddy Turbulent Flow Indicator

Model Number

FC3 - B - E - Q

Brass End Caps

1/4"NPT	FC2
1/4"BSPP	FC2B
3/8"NPT	FC3
3/8"BSPP	FC3B

Nylon End Caps

1/4"NPT	FCP2
1/4"BSPP	FCP2B
3/8"NPT	FCP3
3/8"BSPP	FCP3B

Scale Units

E	English (Temp in °F and Flow in GPM)
M	Metric (Temp in °C and Flow in LPM)

Accessories

B	Thermometer (standard)
E	Thermometer with quick-connect socket and plug

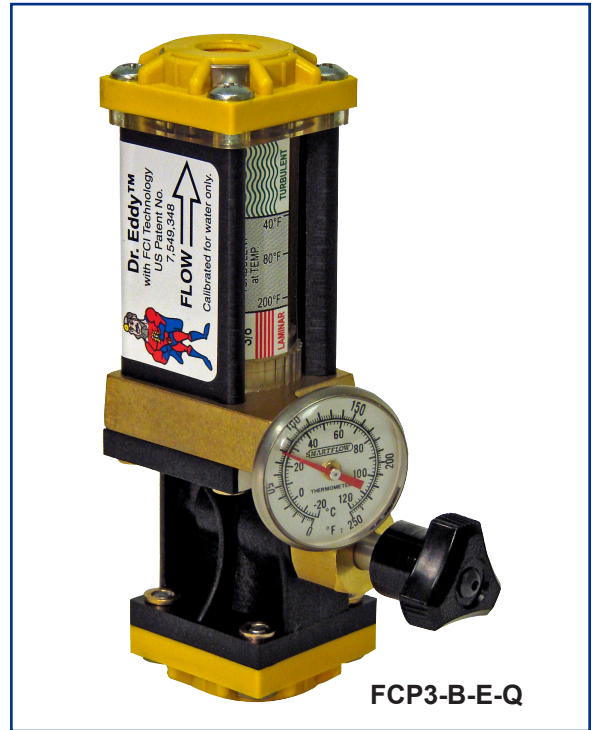

FCP3-B-E-Q

Wetted Parts and Materials

End Caps.....	Brass or Glass-Filled Nylon
Regulator Body.....	Glass-Filled Nylon
Flow Body.....	Polysulfone
Indicator Ring	Silicone Rubber
Piston.....	Acetal
Spring	Stainless Steel
O-Rings	EPDM
Optional Gauge Block.....	Brass
Optional Quick-Connect Fittings.....	Brass

Specifications

Flow Range	0.25 - 2 gpm 1 - 8 lpm
Accuracy.....	±10% full scale
Operating Temperature max.....	210°F (99°C)
Operating Pressure max.....	100 psi (6.9 bar)
Dial Thermometer.....	0 to 250°F (-20° to 120°C) ±2% accuracy (full scale)

Dr. Eddy is calibrated for use with water only. A 10% glycol scale is available on request.

The addition of glycol to cooling water can have a dramatic effect on Turbulent Flow, increasing the flow rate needed to achieve optimum cooling efficiency.

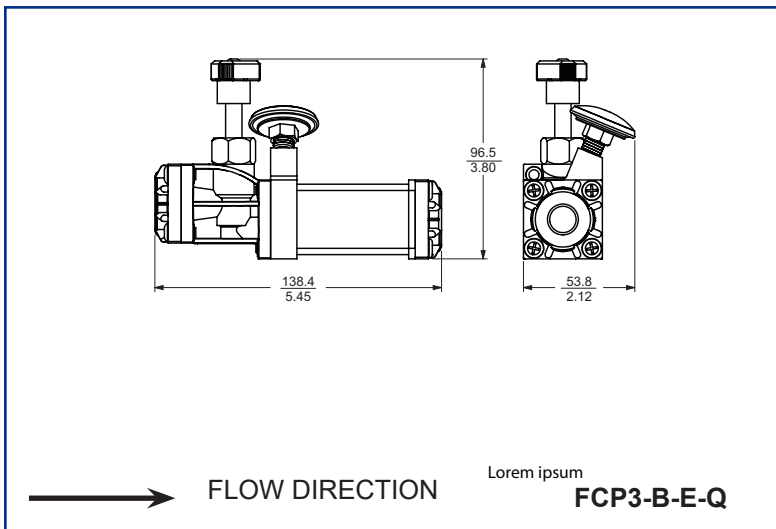

Assembly Specification

The Smartflow manifold line is the platform to control and direct cooling water in many types of industrial process cooling. Flowmeters, Flow Regulators, Ball Valves, Quick Disconnect Fittings and more can be added to manifolds to improve functionality and process control. Individual cooling lines can be accurately controlled according to the demands of each circuit.

Parallel Stainless Steel Manifold Assemblies are built with flowmeters on one half of the manifold pair only. Contact the factory if alternate configuration is needed.

Burger & Brown Engineering recommends placing flowmeters and regulators on the return side of the cooling loop for best performance.

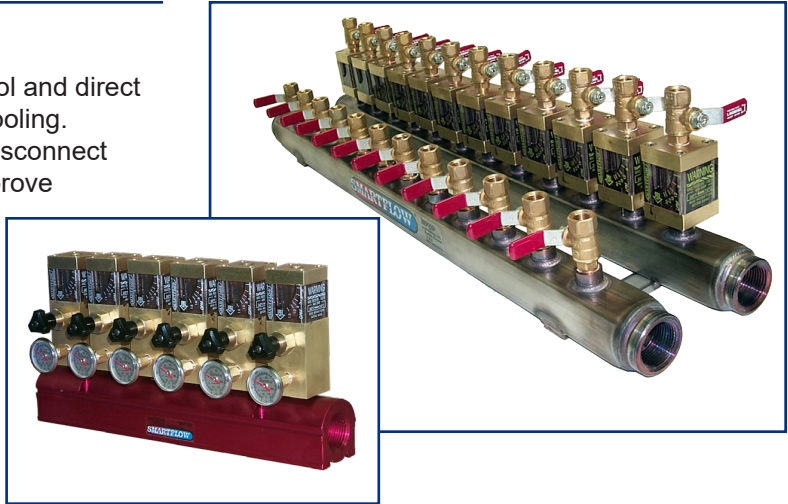

Model Number

Manifold P/N	8SA - 8 - 3 - 2 - Y	F3-A-80	B3Q3	R
	<p>Aluminum or Stainless Steel Manifold Consult Catalog Form #188</p>			<p>Function</p> <p>R Return fluid flow entering the manifold (default)</p> <p>S Supply fluid flow exiting the manifold</p>
	<p>*Flowmeter/Regulator installed on each port of the manifold</p> <p>No additional flowmeter/regulator</p> <p>Mechanical Flowmeter</p> <p>Brass Flow Regulator</p> <p>Delta-Q Precision Flow Regulator (pages 3 thru 15)</p> <p>Tracer® Electronic Flowmeter</p> <p>Tracer_{VM} Electronic Flowmeter</p> <p>See Tracer Catalog number 190</p>	<p>NA</p> <p>F</p> <p>FR</p> <p>F-Q</p> <p>DD</p> <p>VM</p>	<p>Connection Type Brass Valves and Fittings</p> <p>NA No additional valve or fitting</p> <p>B2 Ball Valve 1/4"NPT</p> <p>B3 Ball Valve 3/8"NPT</p> <p>B4 Ball Valve 1/2"NPT</p> <p>H2 Hose Barb 1/4"ID Hose</p> <p>H3 Hose Barb 3/8"ID Hose</p> <p>H4 Hose Barb 1/2"ID Hose</p> <p>Q2 Quick Connect Plug 1/4"ID (200 Series)</p> <p>Q3 Quick Connect Plug 3/8"ID (300 Series)</p> <p>Q4 Quick Connect Plug 1/2"ID (500 Series)</p>	

ManifoldBuilder.com

On-Line Part Number Specification Assistance

3D Native CAD files for manifolds and assemblies are available for download 24/7 at www.manifoldbuilder.com